

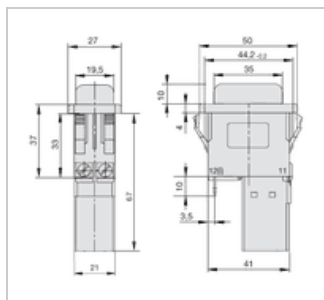

## E-T-A circuit breaker X3120-F504-G7Q1-W04D

Manufacturer:	E-T-A
Type:	3120-F504-G7Q1-W04D - X3120-U0000M
Product no.:	X3120-F504-G7Q1-W04D
Weight:	0.050

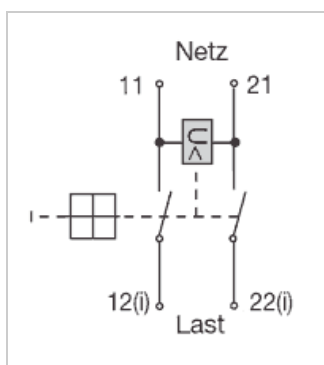

### ■ Details

Insert switch with undervoltage release

### ■ Properties

- 2-pole off-switch
- Without overcurrent protection
- With undervoltage release
- With splash water proof cover IP54
- Rocker switch red with labelling 0-I
- Replacement for Weber Unimat WN 22-551 (refer to explanation)

### ■ Usagesbeispiele

- Kapp- and mitre saw Elu TGS 171, refer to [Usage of Elu TGS 171](#)
- Kapp- and mitre saw Einhell KGTN 245

### ■ Important while replacing a Weber Unimat WN 22-551 or WN 22-555

Both switches are available in different variations, without being exactly specified on the type plate.

This E-T-A switch is a suitable replacement for Weber Unimat WN 22-55x suitable:

- Switch with 4 connections P1, P2, 3, 4
- Switch with connection 5 as auxiliary contact without switching function.  
Diese construction was used for example in the mitre saw Elu TGS 171 verwendet.

### ■ Dimensions

<b>Installation opening</b>	44.5 x 22 mm (clamping thickness 1-4 mm)
<b>Collar height</b>	2 mm with splash water proof cover IP54
<b>Collar (cover)</b>	50 x 27 mm with splash water proof cover
<b>Installation depth</b>	67 mm

### ■ Specifications

<b>Nominal voltage</b>	AC 240 V; DC 50 V
<b>Switching current max.</b>	16 A
<b>Protection class</b>	Operating area IP54, connecting area IP00
<b>Isolation</b>	Reinforced in the actuation element
<b>Ambient temperature</b>	-30 . 60 °C
<b>Switch</b>	2-pole
<b>Approval</b>	VDE, BV, CSA/UL, CCC
<b>Installation</b>	Snap-on frame
<b>Connection</b>	



	On the mains: clamp screw M3.5 Under load: flat plug 6.3 mm (2 x 2,8 mm)
<b>Circuit breaker norm</b>	EN 60934/IEC 60934: S-Typ, TO